

**BROEN BALLOMAX<sup>®</sup>**  
POLYETHYLENE BALL VALVES



## CONTENTS

I.	INTRODUCTION .....	3
	Technical Manual Release Date .....	4
	Scope .....	5
	Applicable Standards and Regulations .....	5
	Manufacturing Approach .....	5
II.	QUALITY ASSURANCE AND CONTROL .....	6
	The BROEN Quality Management System.....	7
III.	ENGINEERING DETAILS .....	17
	Polyethylene Resins.....	18
	Materials .....	21
	Butt Fusion Procedure and Parameters .....	22
	Fusion Compatibility of BROEN BALLOMAX Ball Valve with Polyethylene Gas Pipe and Tubing .....	24
IV.	TESTING CODE AND COMPLIANCE .....	25
	Production Test According to ASME B16.40 Section 6.2.....	26
	Qualification test According to ASME B16.40 Section 6.3 .....	26
	Additional Extra Test .....	29
V.	STANDARD VALVE PROCEDURES.....	31
	Installation and Field Test Procedures .....	32
	Valve Handling, Transportation, and Shipment .....	32
	Shelf Life .....	32
	Valve Maintenance.....	33
VI.	ADDITIONAL VALVE INFORMATION .....	34
	Gear Box Information.....	35
	Marking and Traceability in Compliance with ASME B16.40 and ASTM F2897 .....	36
	Troubleshooting .....	37

## I. INTRODUCTION

Technical Manual Release Date

# BROEN

## BALLOMAX®

All information contained in this manual is the exclusive property of **BROEN Inc.** Any reproduction or use of the calculations, drawings, photographs, procedures, or instructions, either expressed or implied, is forbidden without the written permission of **BROEN Inc.** or its authorized agent.

Initial Release: June, 1997

Latest Revision: February 8, 2024. Prepared by: Bryan Ham

Approved By:

Mogens Laursen, CEO BROEN A/S

---

BROEN A/S

Ben Marchisio, President

---

BROEN Inc.

Copyright© 1997 all rights reserved  
By **BROEN Inc.**

**BROEN Inc.**  
6421 Lozano Dr  
Houston TX 77041  
Phone: 713-300-0480  
[www.broen.us](http://www.broen.us)

## Scope

This Technical Manual provides information about the Polyethylene Ball Valves made by BROEN, with the BALLOMAX® brand.

These valves are available in the following sizes:

- 1/2" thru 8" PE 80 / PE 2708
- 1/2" thru 16" PE 100 / PE 4710

## Applicable Standards and Regulations

ASME B 16.40

ASTM D2837

ASTM D2513

ASTM D3261

ASTM D3350

ASTM F2897

EN 1555-4

ISO 9001:2015

ISO 9080

ISO 4437

D.O.T Title 49, Part 192

Plastic Piping Institute - Technical Report TR-33 / 2001 "Generic Butt Fusion Joining Procedure for Polyethylene Gas Pipe".

\*CSA Z662 using 0.45 Design Factor

\*ASTM using .040 Design Factor

\*Based on SDR 11 Wall Thickness

## Manufacturing Approach

BROEN BALLOMAX Polyethylene valves are made in South Korea by Daeyoun. Daeyoun is the BROEN's manufacturing partner for these products and the relation between the two parties is regulated by a long lasting exclusive agreement. Daeyoun operates in a state of the art manufacturing facility located in Asan, using modern equipment and continuously investing to increase capacity, improve quality, and ensure efficiency.

## II. QUALITY ASSURANCE AND CONTROL

### **The BROEN Quality Management System**

Both BROEN and Daeyoun are ISO 9001:2015 certified.

Both companies operate following procedures described by their Quality Management System, which is periodically audited (internally and by 3rd parties) and continuously updated and improved.

## BROEN ISO 9001 Certificate

Bureau Veritas Certification



**BROEN A/S**

Skovvej 30, 5610 Assens, Denmark

This is a multi-site certificate, additional site(s) are listed on the next page(s)  
*Bureau Veritas Certification Holding SAS – UK Branch certifies that the Management System of the above organisation has been audited and found to be in accordance with the requirements of the management system standards detailed below*

---

**ISO 9001:2015**

*Scope of certification*

---

**Development, manufacturing, engineering and delivery of valves to District Energy & Gas, Building Installations & Control, Industrial Installations & Control, & Control valve solutions to Marine, Power & Energy.**



Original cycle start date:	10-07-1991
Expiry date of previous cycle:	NA
Certification / Recertification Audit date:	NA
Certification / Recertification cycle start date:	16-09-2021
Subject to the continued satisfactory operation of the organization's Management System, this certificate expires on:	15-09-2024

Certificate No.: **DK014631**    Version: **2**    Issue date: **03-02-2022**



---



0008

Certification Body Address: 5th Floor, 66 Prescott Street, London, E1 8HG, United Kingdom  
Local Office: Bureau Veritas Certification Denmark A/S, Oldenborggade 25-31, 7000 Fredericia

Further clarifications regarding the scope and validity of this certificate, and the applicability of the management system requirements, please call: (+45) 77 311 000.



1/3

**BROEN**  
BALLOMAX®

*Designed to last*

8





BUREAU  
VERITAS

Bureau Veritas Certification

## BROEN A/S

### ISO 9001:2015

Scope of certification

Site Name/Location	Site Address	Site Scope
BROEN A/S (Head Office)	Skovvej 30, 5610 Assens, Denmark	Development, manufacturing, engineering and delivery of valves to District Energy & Gas, Building Installations & Control, Industrial Installations & Control, & Control valve solutions to Marine, Power & Energy.
BROEN Clorius (Clorius Controls)	ul. Strefowa 19, pl-58-200 Dzierzoniow, Poland	Manufacturing, engineering, and delivery of control valve solutions to Marine, Power & Energy.  Manufacturing and assembly of valves to Building Installations & Control.
BROEN Inc. (USA)	6421 Calle Lozano Dr., 77041 Houston, USA	Development, manufacturing, engineering, delivery and service of valves actuators and controllers to District Energy & Gas, Building Installations & Control and Industrial Power & Energy
BROEN POLAND sp. z o.o. (Pleszycka)	ul. Pleszycka 10, pl-58-200 Dzierzoniow, Poland	Development, manufacturing, engineering and delivery of valves to District Energy & Gas, Building Installations & Control and Industrial Installations & Control.

Certificate No.: **DK014631**    Version: **2**    Issue date: **03-02-2022**

*Phil Absalonsen*



0008

Certification Body Address: 5th Floor, 66 Prescott Street, London, E1 8HG, United Kingdom

Local Office: Bureau Veritas Certification Denmark A/S, Oldenborggade 25-31, 7000 Fredericia

Further clarifications regarding the scope and validity of this certificate, and the applicability of the management system requirements, please call: (+45) 77 311 000.



## DAEYOUN ISO 9001 Certificate





### Certificate of Quality Management System

## DAEYOUN Co., Ltd.

Issue No : QC-0008-H(0)

KGS certifies that The Quality Management System  
of the above organization has been assessed and found to be  
in accordance with the requirements of the standard  
and scope of certification detailed below

Standard : KS Q ISO 9001:2015 / ISO 9001:2015

Scope : Development, Production and Service of PE Pipe Fitting,  
PE Ball Valve

Initial certification date : 1999. 11. 10.  
Valid period : 2020. 11. 10. ~ 2023. 11. 09.  
Issue date : 2020. 11. 19.

Site of certificate  
23, Dosong-ro, Dogo-myeon, Asan-si, Chungcheongnam-do, Korea

Lead Assessor : Ko Han-young



www.kgs.or.kr



KAB-QC-22

### KGS

KOREA GAS SAFETY CORPORATION

1390 Wonjung-ro, Maengdong-myeon,  
Eumseong-gun, Chungcheongbuk-do, Korea



Korea Gas Safety Corporation has been designated by Korea Accreditation Board  
as a QMS(Quality Management System) certification body.(Licence No. KAB-QC-22)

Certificate of Regulation

Letter of Guarantee from the Manufacturer: Compliance to ASTM D2837 and ISO 9080

PE Valves & Fittings

**DAEYOUN CO., LTD.**

## THE LETTER OF GUARANTEE

To : Whom it may concern,

This is to confirm that DAEYOUN CO.,LTD. PE4710 Grade Valves, including Valve Private labeled "BROEN BALLOMAX" for the U.S. market in sizes 3/4 inch through 16 inch are able to meet the U.S 125 PSI and the Canadian 145 PSI of Maximum Operating Pressure requirement. Our PE4710 resin is listed in PPI TR-4 and complies with ASTM D2837 and ISO 9080.

Sincerely,

DAEYOUN CO.,LTD.

DAEYOUN CO.,LTD  
23, Dosong-ro, Dogo-myeon, Asan-si  
Chungcheongnam-do, 31554, Korea



**DAEYOUN  
POLYETHYLENE SYSTEM**

To meet your requirement, we will not stop developing quality assurance system.  
[www.daeoun.kr](http://www.daeoun.kr)

**Declaration of Conformity: Compliance to ASME B16.40 - 2019**

*Declaration of conformity: compliance to ASME B16.40 - 2019*



**DAEYOUN CO., LTD.**

Company Name : DAEYOUN CO., LTD.

Address : 23, Dosong-ro, Dogo-myeon, Asan-si, Chungcheongnam-do 31554, Korea

The Undersigned Company certifies under its sole responsibility that item of equipment specified below satisfies the requirements of the pressure equipment directive 97/23/EC which apply to it.

The item of equipment identified below has been subject to internal manufacturing checks with monitoring of the final assessment under module A1 of the pressure equipment directive, by TUV Nord group (notified body number 0045)

Equipment : Polyethylene (PE) Ball Valve

Description : 3/4", 1", 1 1/4", 2", 3", 4", 6", 8", 10", 12", 14", 16"IPS

Serial number(s) : \_\_\_\_\_

Harmonized standards applied : ASME B 16.40-2019

Other technical standards and specifications used : ISO, ANSI, KS, CE / ASME, GB

SIGNED ON BEHALF OF THE MANUFACTURE / AUTHORIZED REPRESENTATIVE

Name : D. H. LEE

Position : General Manager

Place / Date : KOREA, 11/25/2019

Signature : \_\_\_\_\_  

## Third Party Certificate of Compliance to ASME B16.40

Certificate No. 156131602-100-IC-001

### INSPECTION CERTIFICATE

Date: 16 July 2020

Applicant / Manufacturer : DAEYOUN CO., LTD.  
Inspection Place : 23,Dosong-ro,Dogo-myeon,Asan-si, Chungcheongnam-do  
31554, Korea  
Technical Specification : ASME B16.40- 2015 edition  
Kind of test : Witness of annex 1  
Inspection Description : Manually Operated Gas Valve as the details  
Material / Colour : PE100 / Black  
( Pipe designation of ASTM D2513 )

#### DETAILS

- ASME B16.40 Manually Operated Thermoplastic Gas Shutoffs and valves in Gas Distribution System as the below valve size
  - 1" IPS
  - 4" IPS
  - 12" IPS

**This is to certify that the testing and inspection as the annex 1. was performed by the manufacturer facility under inspector's witness as the above, and the results were satisfied within acceptance of criteria specified in accordance with the purchaser's specification and applicable standard.**

The issue of this document does not relieve the supplier/manufacturer from its responsibility to its client to supply the item concerned in full compliance with the requirements of its client Specification.

Place and date of issuance : Changwon, Korea / 16 July 2020

Initials of inspector : Hee-Dong Park

PLEASE STAMP HERE



www.tuv.com

TÜV Rheinland Korea Ltd.

(KR-001) Signature on  
Industrial Inspection Manager

 **TÜV Rheinland®**  
Precisely Right.

Certificate No. 156131602-100-IC-001

## TEST RESULTS

### Annex 1

Inspection No. - 156131602-100-IC-001  
Page 1/1

There are 8 kinds of test in ASME B16.40, Paragraph 6.  
All test result for each valve size are as following.

Required Test *	Size of Valves ( unit : inch IPS )		
	1"	4"	12"
Shell Test	O	O	O
Seat Test	O	O	O
Operational Test	O	O	O
Temperature Resistance	O	O	O
Sustained Pressure Test	O	O	O
Impact Resistance	O	O	O
Appearance, Colour, Marking	O	O	O
Dimension	O	O	O

Note 1) \* : Required test. for each test method is the test order of ASME B16.40 Paragraph 6.  
2) \*\* : Not Applicable  
3) O : Accepted

Place  
Changwon, Rep.of Korea

Date  
16. July, 2020

Industrial Inspection and Material Testing

www.tuv.com



(KR-001) Hee-Dong PARK

**TÜV Rheinland**<sup>®</sup>  
Precisely Right.

## Third Party Certificate of Compliance to ASTM D2513

Certificate No. 156150224-100-IC-001

### INSPECTION CERTIFICATE

Date: 04 November 2022

Applicant / Manufacturer : DAEYOUN CO., LTD.  
Inspection Place : 23,Dosong-ro,Dogo-myeon,Asan-si, Chungcheongnam-do  
31554, Korea  
Technical Specification : ASTM D2513- 2019 edition  
Kind of test : Witness of annex 1  
Inspection Description : Polyethylene Valve as the details  
Material / Colour : PE4710 / Black  
( Pipe designation of ASTM D2513 )

#### DETAILS

- ASTM D2513 Polyethylene ball valve as the below valve size
  - 2" IPS
  - 4" IPS
  - 6" IPS

**This is to certify that the testing and inspection as the annex 1. was performed by the manufacturer facility under inspector's witness as the above, and the results were satisfied within acceptance of criteria specified in accordance with the purchaser's specification and applicable standard.**

The issue of this document does not relieve the supplier/manufacturer from its responsibility to its client to supply the item concerned in full compliance with the requirements of its client Specification.

Place and date of issuance : Seoul, Korea / 04 November 2022

Initials of inspector : Hee-Dong Park

PLEASE STAMP HERE



www.tuv.com

TÜV Rheinland Korea Ltd.

(KR-001) Signature on  
Local Field Manager

 **TÜVRheinland®**  
Precisely Right.

Certificate No. 156150224-100-IC-001

## TEST RESULTS

### Annex 1

Inspection No. : 156150224-100-IC-001  
Page 1/1

There are 8 kinds of test in ASTM D2513, Paragraph 6.  
All test results for each valve size are as following.

Required Test *	Size of Valves ( unit : inch IPS )		
	2"	4"	6"
Dimension	O	O	O
Sustained Pressure Test	O	O	O
Minimum Hydrostatic Burst Pressure	O	O	O
Apparent Tensile Properties	O	O	O
Chemical Resistance	O	O	O
Appearance, Colour, Marking	O	O	O

Notes 1) \* : Required test. for each test method is the test order of ASTM D2513 Paragraph 6.  
2) \*\* : Not Applicable  
3) O : Accepted

Place  
Seoul, Rep.of Korea

Date  
04. November, 2022

Industrial Inspection and Material Testing

(KR-001) Hee-Dong .Park

www.tuv.com

 **TÜVRheinland®**  
Precisely Right.



### III. ENGINEERING DETAILS

## Polyethylene Resins

BROEN BALLOMAX Polyethylene Valves are manufactured of one of the following resins:

### **PE 80 / PE 2708 Medium Density Yellow**

**Maker and brand: BOREALIS BORSAFE ME3441**

BOREALIS ME3441 meets the requirements of ISO 12162 as PE 80.

BOREALIS ME3341 is listed in PPI Technical Report TR-04-2021.

Temperature range of this valve is -20°F / 140°F.

The full range of BROEN BALLOMAX valves made with this PE 80 resin, with SDR 11 wall thickness, are able to meet the 80 PSI Maximum Operating Pressure requirement for the US gas market and the 100 PSI Maximum Operating Pressure requirement for the Canadian gas market.

The maximum operating pressure for water service for the BROEN BALLOMAX valves made with this PE 80 resin is 145 PSI.

### **PE 100 / PE 4710 High-Density Black**

**Maker and brand: INEOS TUB 121**

INEOS TUB 121 meets the requirements of ISO 12162 as PE 100.

INEOS TUB 121 is listed in PPI Technical Report TR-04-2021.

Temperature range of this valve is -20°F / 140°F.

The full range of BROEN BALLOMAX valves made with this PE 100 resin, with SDR 11 wall thickness, are able to meet the 125 PSI Maximum Operating Pressure requirement for the US gas market and the 145 PSI Maximum Operating Pressure requirement for the Canadian gas market.

The maximum operating pressure for water service for the BROEN BALLOMAX valves made with this PE 100 resin is 188 PSI.

**Please note: BROEN/DAEYOUN reserves the right change the resins brand and model without notice, provided that resins properties are equal or superior.**

## Resin Datasheets



### Polyethylene

# BorSafe™ ME3441

Yellow medium density Polyethylene compound for pressure pipes

### Description

BorSafe ME3441 is a bimodal polyethylene compound produced by the advanced Borstar techno

It includes a combination of pigments and stabilisers to ensure excellent long-term thermal stability resistance.

BorSafe ME3441 is classified as an MRS 8.0 material (PE80).

### Applications

BorSafe ME3441 is recommended for pressure pipe systems in the applications field of:

Natural gas

Particularly where flexibility and coilability is of importance. It also shows excellent resistance to rap propagation and slow crack growth. Thanks to the structure, it gives outstanding extrudability, comp conventional PE80.

### Physical Properties

Property	Typical Value	Test Method
	Data should not be used for specification work	
Density	944 kg/m <sup>3</sup>	ISO 1183
Melt Flow Rate (190 °C/5,0 kg)	0,80 g/10min	ISO 1133
Tensile Modulus (1 mm/min)	800 MPa	ISO 527-2
Tensile Strain at Break	> 500 %	ISO 527-2
Tensile Stress at Yield (50 mm/min)	19 MPa	ISO 527-2
Oxidation Induction Time (200 °C),	> 20 min	EN 728
Resistance to rapid crack propagation (S4 test, Pc at 0 °C, Test pipe 250 mm, SDR11)	6 bar	ISO 13477
Resistance to slow crack growth (8 bar, 80 °C)	> 2.000 h	ISO 13479

### Processing Techniques

Note: Please check Borealis website for the most update and comprehensive information, including MSDS.



# ELTEX<sup>®</sup> TUB121

## Product Technical Information

ELTEX<sup>®</sup> TUB121 is a high-density polyethylene copolymer designed for injection moulding of pipe. It is characterized as PE 100 Black pipe compound.

## Benefits & Features

ELTEX<sup>®</sup> TUB121 is classified PE 100 in accordance with ISO 12162 based on ISO 9080 analysis. ELTEX<sup>®</sup> TUB121 is specifically recommended for injection moulding of fittings.

## Applications

- Gas
- Water
- Industrial

Properties	Conditions	Test Methods	Value
<b>Rheological</b>			
Melt Flow Rate	190°C/5 kg	ISO 1133-1	0.45
<b>Physical</b>			
Density ISO 1872-1	23°C	ISO 1183-1	959
<b>Mechanical</b>			
Tensile Strength at Yield	23°C	ISO 527-2	25
Tensile strain at Break	23°C, 50 mm/min	ISO 527-2	>350
Tensile Modulus	23°C, 1 mm/min	ISO 527-2	1100

Note: Please check Ineos' website for the most update and comprehensive information, including MSDS.

## Materials

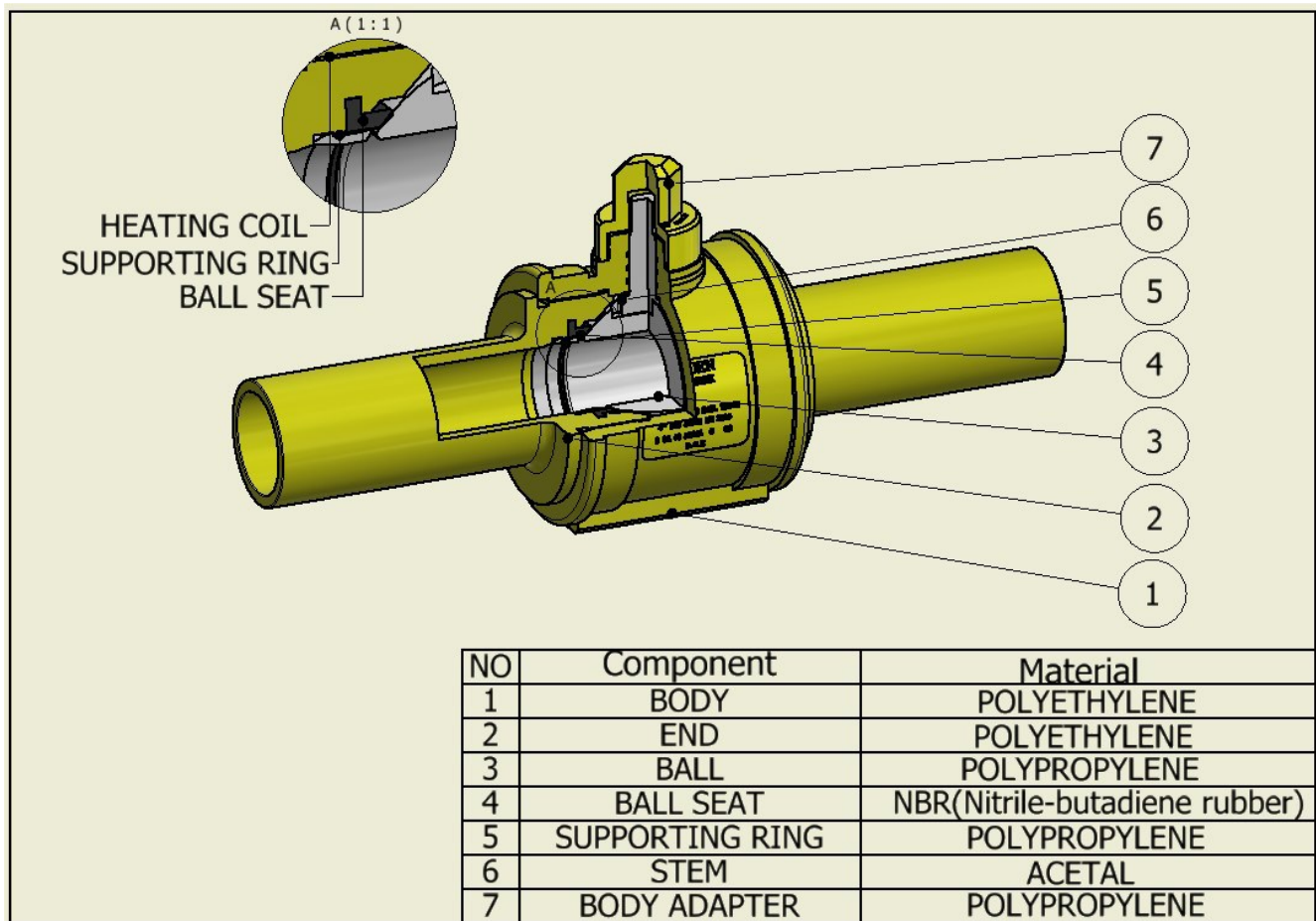

## Butt Fusion Procedure and Parameters

The intent of this section is to verify the compatibility of Butt Fusing PE Pipe material to the ends of the BROEN BALLOMAX Valve.

The fusion data in this report is based on Butt Fusion Procedures determined and established by BROEN BALLOMAX and the qualification procedures as provided in Section 192.283 of the D.O.T Title 49, Part 192 regulations. Pressure and tensile tests used are described in Section 192.283, CFR.

Standard Valve ends are SDR 11. BROEN approves butt fusion of one SDR difference in the pipe wall. Care should be taken to adjust for the thinner wall pipe during fusion.

For other SDR's available on the valve contact your BROEN representative.

BROEN INC. has reviewed the Plastic Piping Institute - Technical Report TR-33 / 2001 "Generic Butt Fusion Joining Procedure for Polyethylene Gas Pipe".

Based on in house testing, in accordance with DOT 192.283 for qualifying joining procedures, tensile tests per ASTM D638 and quick burst tests per ASTM D2513, we concur with the use of the Generic Butt Fusion Parameters and Procedures in the joining of our BALLOMAX Valves.

Care should be taken to follow the fusion equipment manufacturers recommended instructions to determine if the equipment is properly serviced and capable of achieving a suitable fusion. Place the clean valve and pipe end into the jaws of the equipment and pre-align. Properly face off the ends to a smooth even finish. Insert clean, proper temperature heater, and apply the proper interfacial pressure.

### Procedure:

1. Clean Valve and Pipe end and install and align in fusion equipment.
2. Face off the end of the valve and pipe end and check for gaps in the fusion area.
3. Check for any high/low adjustment that is necessary.
4. Verify proper heater plate temperature, wipe clean, and insert between pipe and valve end.
5. Bring valve and pipe ends into contact with heater with enough pressure to maintain contact.
6. Use the table below to determine the proper heating time and bead size needed to make a suitable butt fusion joint.
7. Remove heater and bring the valve and pipe ends together quickly, applying pressure to create a "double roll back bead".
8. Maintain pressure in the joined area according to the "Cooling Time" listed below. (Note additional cooling time is required before direct burial of the pipe and valve.)
9. Inspect the butt fusion joint for quality.

BROEN recommends the heater surface temperature be set at 400-450F for Butt Fusion.  
Please note that the recommended temperature for Socket Fusion is 500F ± 10F.

### Butt Fusion Parameters for PE 80 / PE 2708

Size	Heat Time [sec]	Bead Size	Cooling Time [min]
1-1/4"	11-15	1/8"	1.0
2"	16-20	1/8"	1.0
3"	20-24	1/8"	1.5
4"	26-30	3/16"	3.0
6"	42-50	3/16"	3.5
8"	58-66	1/4"	4.0

Note: Fusion Times are estimated and based on 70°F

### Butt Fusion Parameters for PE 100/ PE 4710

Size	Heat Time [sec]	Bead Size	Cooling Time [min]
1-1/4"	23-26	1/8"	1.5
2"	28-32	1/8"	1.5
3"	32-38	1/8"	3.0
4"	38-44	3/16"	3.5
6"	56-66	3/16"	4.0
8"	72-88	1/4"	4.5

Note: Fusion Times are estimated and based on 70°F

## Fusion Compatibility of BROEN BALLOMAX Ball Valve with Polyethylene Gas Pipe and Tubing

The data presented in this report is based on Butt Fusion Procedures established by BROEN BALLOMAX and the qualification procedures in accordance with D.O.T. Title 49 CFR Part 192.

The intention of this report is to verify the compatibility of Butt Fusion Joining PE Piping Systems to the Pipe Ends (Pup Ends) of the BROEN BALLOMAX Polyethylene Ball Valve.

This report is the property of BROEN Inc. and is loaned subject to the conditions that it or any information contained within will not be used in any way detrimental to the interest of BROEN Inc. and that all copies will be returned immediately on demand.

Butt Fusion Compatibility has been performed for:

- PE 80 / PE 2708 Medium Density Polyethylene Valves
- PE 100 / PE 4710 High Density Polyethylene Valves

All tests were conducted in accordance with D.O.T. Title 49 Part 192 and the prevailing ASTM Standards.

All fusion joints were made according to the fusion procedures established by BROEN Inc.

### Butt Fusion Test Results

BROEN BALLOMAX BALL VALVE 2" PE 80 <=> U.S. Poly

#### A: Burst test per ASTM D 2513 and D 1599

Sample #	Valve Ends		Pipe		Burst Strength [psi]	Burst Time [sec]	Burst Stress [psi]
	OD [inch]	Min. Wall Thickness [inch]	OD [inch]	Min. Wall Thickness [inch]			
1	2.37	0.22	2.37	0.22	652	64	3190
2	2.37	0.22	2.37	0.22	655	65	3189
3	2.37	0.22	2.37	0.22	653	66	3156

**All Failures Outside of Fusion Joint.**

### Tensile Elongation at break per ASTM D 638

Elongation on type II specimen cut from Butt Fusion assemblies.

Sample #	Test Specimen Length [inch]	Extension [inch]	Elongation at Break	Yielding number
1	2.0	6.0	>25%	PIPE
2	2.0	6.0	>25%	PIPE
3	2.0	6.0	>25%	PIPE



## IV. TESTING CODE AND COMPLIANCE

## **Production Test According to ASME B16.40 Section 6.2**

Each valve (100% of pieces) is subject to the two tests described below.

### **Shell Test according to ASME B16.40 Section 6.2.1**

Parameters:

Test performed under water with compressed air as test media.

P1= 1.5x design pressure

P2= 4 PSI

T = 73°F ± 15°F (23°C ± 8°C)

Requirements:

No leaks recorded

### **Seat Test according to ASME B16.40 Section 6.2.2**

Parameters:

Test performed under water with compressed air as test media.

P1 = 1.5x design pressure

P2 = 4 PSI

T = 73°F ± 15°F (23°C ± 8°C)

Requirements:

No leaks recorded.

## **Qualification test According to ASME B16.40 Section 6.3**

Each basic valve design is qualified by testing randomly selected production valves in accordance with the tests described by the following paragraphs.

### **Operational test torque according to ASME B 16.40 Section 6.3.1**

Parameters and values:

Test pressure: Design pressure; Full differential

Number of cycles: 10 cycles

Test temperature: 73°F ± 15°F (23°C ± 8°C)

Test fluid: air

Requirements:

No leakage and operating torque not exceeding values in Table 6.3.1 for -20°F (-29°C)

## **Temperature resistance according to ASME B16.40 Section 6.3.2 – Low temperature test**

Parameters and values:

Test pressure: Design pressure; Full differential

Test temperature:  $-20^{\circ}\text{F} \pm 5^{\circ}\text{F}$  ( $-29^{\circ}\text{C} \pm 3^{\circ}\text{C}$ )

Test fluid: air or other gas

Test duration: 18 hours

Requirements:

No leakage and operating torque not exceeding values in Table 6.3.1

## **Temperature resistance according to ASME B16.40 Section 6.3.2 – High temperature test**

Parameters and values:

Test pressure: Design pressure; Full differential

Test temperature :  $140^{\circ}\text{F} \pm 5^{\circ}\text{F}$  ( $60^{\circ}\text{C} \pm 3^{\circ}\text{C}$ )

Test fluid: air or other gas

Test duration: 18 hours

Requirements:

No leakage and operating torque not exceeding values in Table 6.3.1

## **Sustained Pressure Test according to ASME B16.40 Section 6.3.3 – Pressure boundary test**

Parameters and values:

Assembly description: 6 valves connected with thermoplastic pipe with length either 5 times OD or 20", whichever is less. All valves in open position

Test pressure: depends on DR and test duration (see Table 6.3.3-1)

Test temperature:  $176^{\circ}\text{F}$  ( $80^{\circ}\text{C}$ )

Test fluid: air or other gas

Test duration: either 1,000 hour at lowest pressure listed in Table 6.3.3-1 or 170 hour at highest pressure listed in same table

Requirements:

No leakage (test criteria per ASTM D1598)

## **Sustained Pressure Test according to ASME B16.40 Section 6.3.3 – Valve closure test**

Parameters and values:

Test pressure: 1.1 times design pressure

Test fluid: air or other gas

Test duration and Temperature: either 1,000 hour at  $100^{\circ}\text{F}$  ( $38^{\circ}\text{C} \pm 8^{\circ}\text{C}$ ) or 170 hour at  $176^{\circ}\text{F}$  ( $80^{\circ}\text{C}$ )

Requirements:

No leakage.

After test valve must be operable at 0 psi and with differential pressure equal to design pressure with torque less than values in 6.3.1 for  $140^{\circ}\text{F}$  ( $60^{\circ}\text{C}$ ), and no leakage"

### Flow capacity Test according to ASME B16.40 Section 6.3.4

Parameters and values:

Test executed according to ANSI/ISA S 75.02.

Test performed with 7 PSI Line Pressure.

T= Fluid Temperature

Pressure Loss= Water Column

Size	Pressure Loss	T [°F]	Flow [ft <sup>3</sup> /h]	Port Size	Cv
2"	.275	43	4,598	1.81	173
3"	.298	43	6,015	2.76	420
4"	.215	43	9,998	3.54	700
6"	.190	43	19,010	5.24	1815
8"	.198	43	25,275	6.89	3800

Requirements:

Flow Capacity to meet or exceed requirement of ANSI/ISA S75.02

### Impact Resistance Test according to ASME B 16.40 section 6.3.5 – Low and high temperature

Parameters and values:

Test performed according to proposed ASME B 16.40 procedures

A. Valve conditioned for 18 hours at 0°F + 5° F

Five impact tests: Drop of "B" 20 pound TUP according to ASTM D2444 from a height of 3 feet at room temperature. Total elapsed time after removal from environmental chamber is less than 2 minutes.

B. Valve conditioned for 18 hours to 100° F + 5° F

Five impact tests: Drop of "B" 20 pound TUP according to ASTM D2444 from a height of 3 feet at room temperature. Total elapsed time after removal from environmental chamber is less than 2 minutes.

Results: Both valves operational

### Shell Test Performed within 5 Minutes of Impact Tests (4.5)

Shell Test pressure verification according to ASME B 16.40 section 6.2.1

Parameters: Test performed in cooled ambient temperature with compressed air as testing media.

P1= 1.5 X design pressure

P2= 4 PSI

T = -20.2 F + 5°F

Valves same as in 4.5

Requirements:

No leaks recorded

## Shell Test pressure verification according to ASME B 16.40 section 6.2.2

Parameters: Test performed with compressed air as test media.

P1= 1.5 X design pressure

P2= 4 PSI

T = 100.4 F + 5°F

Requirements:

No leaks recorded

## Additional Extra Test

Randomly selected samples for each production lot are X-ray tested and cut to verify absence of defects in the materials density. In case a defect is detected, the whole production lot is scrapped. The production parameters are verified and fine tuned to avoid future defects.

## Test Certificate Example



**DAEYOUN CO., LTD.**

23, Dosong-ro, Doga-myeon, Asan-si,  
Chungcheongnam-do 31554, Korea  
TEL : 82-41-546-9966  
FAX : 82-41-546-9965/9923,  
E-Mail : overseas@daeyoun.kr

### VALVE TEST REPORT

- MODEL NO. :
- INVOICE NO. :
- PE COMPOUND GRADE :
- COLOR :
- TEST DATE :

- SIZE & TYPE :
- SERIAL NO. :

- QUANTITY :
- TESTER :

FOR REFERENCE ONLY

#### 1. Production tests

Characteristics	Requirements	Used Tools	Test parameters		Result		
			Parameters	Value			
Shell & Seat test	No leakage during test period	M-10-22	Test pressure	4.06 psi	4.1 psi	shell	Accept
			Duration of test	150.11 psi 2" and smaller 15sec over 2" to 6" 30sec over 6" 60sec		seat	Accept
			Test temperature	73°F	150.1 psi	shell	Accept
			Type of test	Air or gas		seat	Accept
Ball position	Open at shell test Close at seat test						
Dimension	ASTM D 2513-19	AQ-06-01	Outside dia				
			Wall thickness				
Torque	ASME B 16.40-2019	AQ-12-01	Test pressure				Accept
			Test temperature				Accept
			Specification				
Appearance	The valve shall be free from visible cracks, voids, blisters, distortion, dents, injurious inclusions or other defects.					Accept	

#### 2. Qualification tests

Operating torque	<table border="1" style="font-size: small;"> <tr> <th>Nominal valve size</th> <th>Max torque 80°C</th> <th>Max torque -29°C</th> </tr> <tr> <td>1"</td> <td>36N.m</td> <td>68N.m</td> </tr> <tr> <td>2"</td> <td>68N.m</td> <td>136N.m</td> </tr> <tr> <td>3"</td> <td>102N.m</td> <td>152N.m</td> </tr> <tr> <td>4"</td> <td>136N.m</td> <td>204N.m</td> </tr> <tr> <td>5"</td> <td>152N.m</td> <td>238N.m</td> </tr> <tr> <td>6"</td> <td>168N.m</td> <td>253N.m</td> </tr> <tr> <td>8"</td> <td>204N.m</td> <td>442N.m</td> </tr> </table>	Nominal valve size	Max torque 80°C	Max torque -29°C	1"	36N.m	68N.m	2"	68N.m	136N.m	3"	102N.m	152N.m	4"	136N.m	204N.m	5"	152N.m	238N.m	6"	168N.m	253N.m	8"	204N.m	442N.m	AQ-12-01	Test temperature	-20°F (-29°C)	38 N.m	Accept
		Nominal valve size	Max torque 80°C	Max torque -29°C																										
		1"	36N.m	68N.m																										
		2"	68N.m	136N.m																										
3"	102N.m	152N.m																												
4"	136N.m	204N.m																												
5"	152N.m	238N.m																												
6"	168N.m	253N.m																												
8"	204N.m	442N.m																												
	Seat test	Accept																												
140°F (60°C)	20 N.m	Accept																												
	Seat test	Accept																												
Temperature resistance	Test per requirement of ASME B 16.40 at -20°F and 100°F	AQ-29-01	Test pressure	4.06 psi	4.1 psi	Shell Accept																								
				100.08 psi	100.1 psi	Seat Accept																								
				-20°F	100.1 psi	Shell Accept																								
				100°F	100.1 psi	Seat Accept																								
Type of test	Air or gas	Torque	38°C	Accept																										
		-29°C	Accept																											
Sustained pressure test	Requirement of ASME B 16.40-2019	AQ-28-01	Pressure boundary verification	176°F, 170h, 134psi	Accept																									
			Valve closure verification	176°F, 170h, 110.08 psi																										
Impact loading	No leakage and maximum value for operating torque	AQ-38-01	Drop height	3.5 ft	Accept																									
			Mass of striker	30 lb																										
			Test temperature	-0.4°F, 100°F																										
Butt welding (CEE)	ASTM F 2620-13	AQ-41-01	Bead Width		Accept																									
X-RAY	DAEYOUN QC	AQ-30-01	Body,End,Ball	No Void	Accept																									



INSPECTOR :

김진영 sign

MANAGER :

이동영 sign

## V. STANDARD VALVE PROCEDURES

## Installation and Field Test Procedures

BROEN BALLOMAX Polyethylene Ball Valves can be installed and fused into a piping system using standard butt fusion, socket fusion, or electro-fusion equipment and fittings and the appropriate recommended fusion procedures of the method you choose.

Care must be taken to assure that the Ball Valve is clear of debris that may foul the seating area. Remove all Dirt, Rocks, Sand, and P.E. shavings from the Facing or Scraping operation from inside the Valve prior to fusing into the piping system. Trapped Debris will possibly damage seats, and cause the valve to lock up.

### Field testing procedures for Polyethylene Valves are as follows:

- 1.5 times the MAOP of the Valve with the Ball in the open position (PE 100 - Maximum 187.5 PSI Gas)
- 1.1 times the MAOP of the Valve with the Ball in the closed position (PE 100 - Maximum 137.5 PSI Gas)

Care should be taken when not to use the Valve in a High Differential Pressure application, dead end application, or blow-off application. This can cause a Hard Seated condition that affects the operations of the valve.

## Valve Handling, Transportation, and Shipment

All BROEN BALLOMAX® Valves are to be shipped in the FULL OPEN position. Gear Operators, if installed, are factory set and should not be removed or adjusted before or during construction without consulting a factory representative.

## Shelf Life

The main factor affecting the performance of PE valves is their exposure to UV light. As such, we recommend to keep the valves in their original plastic bag and box.

Based on our experience, a conservative estimate of the shelf life for PE valves is the following:

- 3 years for MD valves (yellow)
- 10 years for HD valves (black)

These times are measured starting from the moment when the valves are extracted from their box and plastic bag.

To avoid misunderstandings, we can consider these times starting from the date of delivery of the valves from BROEN factory/warehouse.



## Valve Maintenance

BROEN BALLOMAX Polyethylene Ball Valves are maintenance free and permanently lubricated.

We reference DOT 192.747 of the Pipe Line Safety Regulations, Valve Maintenance: Distribution System which states:

Each valve, the use of which may be necessary for the safe operation of a distribution system, must be checked and serviced at intervals not exceeding 15 month, but at least once each calendar year.

Our recommendation is as follows:

Note in Valve Records and O&M Manual that this is a Permanently Lubricated Polyethylene Distribution System Valve.

Have a proper sized Valve wrench for this valve.

An in service valve should be checked to make sure that the valve is accessible and operable. Is the valve box positioned properly, and is the operating nut on the valve accessible for use of a proper valve wrench.

Check the operations of the valve. Polyethylene Ball Valves are  $\frac{1}{4}$  turn valves. To close the valve rotate  $\frac{1}{4}$  turn to left. To open the valve rotate  $\frac{1}{4}$  turn to the right.

During operations you should observe or listen for leaks.

## VI. ADDITIONAL VALVE INFORMATION

## Gear Box Information

The BALLOMAX PE valves in sizes between 10" and 16" are supplied with Gearboxes with vertical input. The Gearbox castings are in ductile iron, with excellent strength and impact resistance. The Gearboxes are hermetically sealed and suitable for direct burial.

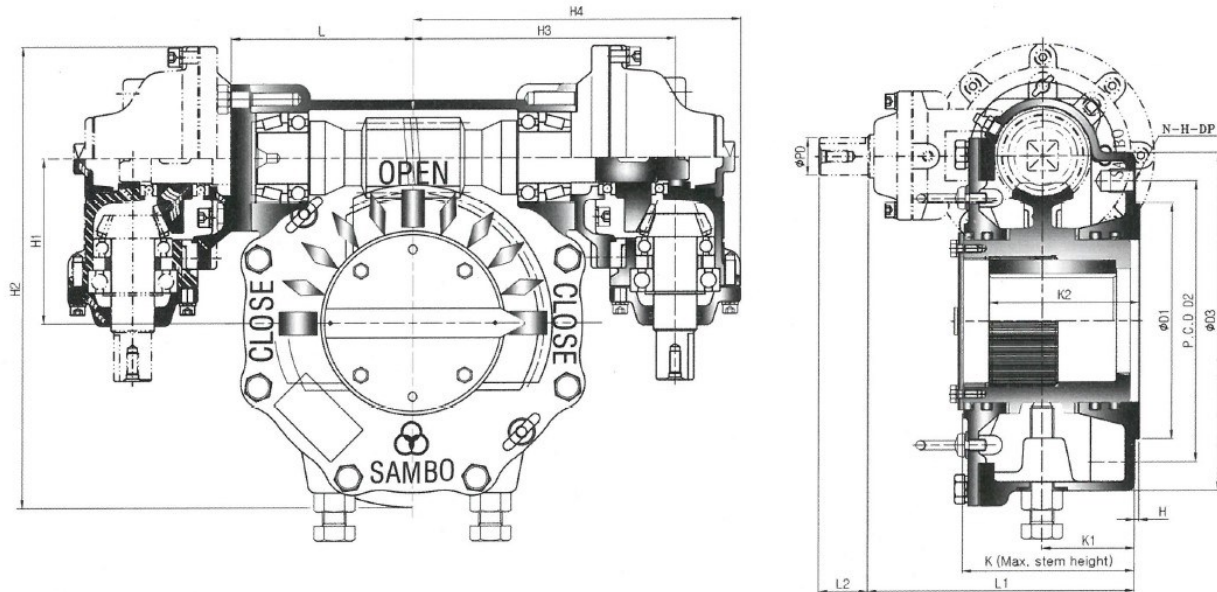

[mm]

Model	Flange	ØD1	H	H2	K	L1	L2
SBWG-00-2B	F-12	85	2	214.5	86.5	132	34

[inch]

Model	Flange	ØD1	H	H2	K	L1	L2
SBWG-00-2B	F-12	3.35	.08	8.44	3.41	5.20	1.34

Gear ratio is 80:1. Weight is 15 kg/33.1 lbs.

## Marking and Traceability in Compliance with ASME B16.40 and ASTM F2897

BROEN BALLOMAX PE valves have a unique serial number to ensure full traceability.

The valve body is marked as follows:



This marking is in full compliance with the requirements of ASME B16.40 and it includes the following information:

- The manufacturer's name (BROEN) and trademark (BALLOMAX)
- The serial number (LOT #), formed by the manufacturing date [yymmdd] followed by a progressive number.
- The NVS (in the picture: 3" IPS)
- The pressure shell material designation code as specified by ASTM D2513 (in the picture: PE 100)
- The DRv (in the picture: SDR 11)
- The date each molded pressure shell part was molded

Valves manufactured starting from January 2020 are also equipped with a 16-digit barcode in full compliance with ASTM F2897 as follows:



The format of this barcode is the following:

BM = "Ballomax" as registered with the Plastic Piping Institute (PPI)

2b1 = Lot code

2ZN = Production Date  
H = PE 4710 Material  
V1 = "Ball Valve" product type  
7 = IPS  
c = 12"  
g = DR 11

For a detailed explanation on how to read this barcode, please refer to ASTM F2897.  
For valves manufactured in the past, the same barcode could be provided upon request.

## Troubleshooting

BROEN BALLOMAX Polyethylene Ball Valves are designed such that there are very few problems that can be experienced. If you do have issues, please call your representative or our office for assistance.

Few remarks:

- If the valve is not sealing, make sure that the valve is in fully closed position.
- Do not over torque the valve in an attempt to close the valve further. The valve closes based on the position of the ball, not the amount of torque applied

**CONTACT BROEN IF YOU NEED ASSISTANCE WITH YOUR BALLOMAX® FLOATING BALL VALVES:**

[info@broen.com](mailto:info@broen.com); +1 713 300 0480.